



Optional leg braces

Formica table



Formica table with
stainless steel drawers

Series 61 Cleanroom Tables, Formica

The Series 61 formica cleanroom tables are designed for use in cleanrooms of Class 100,000 to Class 10. Their heavy-duty design and quality construction will provide, under normal conditions, many years of reliable service. The interior 1-1/8 in. wood core is covered on all surfaces with a high-pressure plastic laminate, creating a table that resists corrosion and is free from particulate generation. This work surface is mounted on a stainless steel support frame with square tubular steel support legs and an adjustable leg-leveling glide. The unit is shipped knocked-down and easily re-assembles. The standard model is manufactured in white. Special order colors are quoted upon request.

Features

- ❖ Stainless steel support frame
- ❖ Compatible with cleanrooms Class 100,000 to Class 10
- ❖ Common sizes in stock for immediate shipping
- ❖ Static dissipative models available

Series 61 Cleanroom Tables

Conductive laminated materials are available for applications where a build up of static charge is problematic. The conductive laminate produces a table with superior conductive qualities. It allows any static build-up to slowly bleed off. The standard color for the conductive table is gray. (White is available as an option.)

Drawers in a variety of sizes can be located on the right, left, or both sides of the table. The drawers slide on roller bearing drawer slides for easy operation. The standard depth of the drawers are 6 in. and 12 in. The standard material for the drawers is stainless steel. Each drawer is furnished with a key lock.

Options

- Adjustable legs 30 in. to 36 in., in 2 in. increments
- Casters
- Conductive table top
- Custom colors
- Drawers
- Foot rest
- Keyboard pull-out trays
- Outlet strips
- Rounded front edge of table top
- Plastic-bottom, leg-leveling glides
- Shelves, upper and lower
- Custom shapes
- Heavy-duty leg bracing (used with casters, heavy loading or with dynamic loads)

Other options available upon request.

Guarantee

A written 1 year warranty is furnished with each cleanroom table.

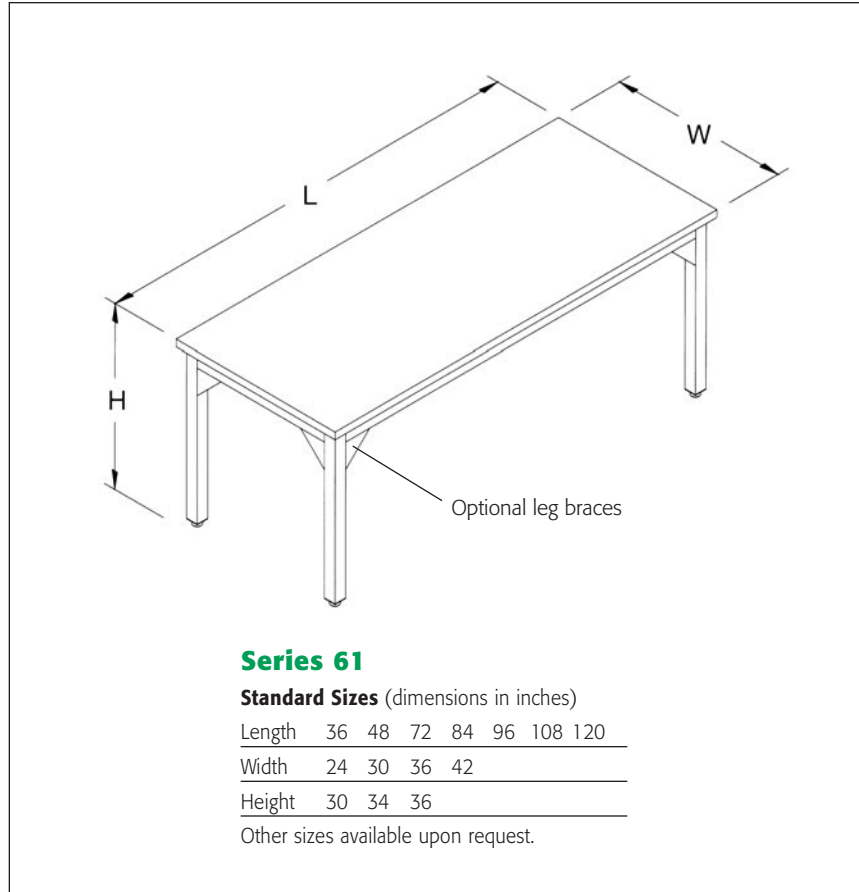

Series 61

Standard Sizes (dimensions in inches)

Length	36	48	72	84	96	108	120
Width	24	30	36	42			
Height	30	34	36				

Other sizes available upon request.

Specifications subject to change. Please contact factory for details.

Clean Air
PRODUCTS

Solutions Built to Your Specifications.

8605 Wyoming Ave. N. • Minneapolis MN 55445

tel: 763.425.9122 800.423.9728 fax: 763.425.2004

e-mail: sales@cleanairproducts.com www.cleanairproducts.com