



Series 412

Vertical Laminar Flow Clean Bench

S
N
O
I
T
U
T
O
S

The Series 412 vertical laminar flow clean benches are specifically designed to create a freestanding ultra-clean mini-environment. These clean benches, or mini-environments, are available in a variety of sizes and styles engineered to provide excellent solutions for many air filtration applications. The systems may vary from vertical flow benches with open interiors to exhausting clean benches with wet process, to recirculating temperature control Class 10 systems.

Clean benches can be used in conjunction with cleanrooms to create clean zones. They can also be used in lieu of or supplemental to a cleanroom. Often times in larger cleanrooms, there are a few "critical clean" areas. It is sometimes more cost-effective to build a lower class cleanroom and supplement it with clean benches, than it is to create a higher class cleanroom. This is especially true when over 60% of a typical cleanroom floor space is area where clean manufacturing or storage does not occur.

Features

- ❖ Standard white enamel finish provides excellent corrosion resistance
- ❖ HEPA filter is 99.99% efficient
- ❖ Open-frame design
- ❖ All-metal welded filter module
- ❖ Structural shell components are a minimum of 16 gage cold rolled steel
- ❖ Support frame is heavy-duty 2 x 4 in. steel tubing
- ❖ Horizontal cross bracing is 2 x 2 in. steel tubing
- ❖ Cool white fluorescent lamps
- ❖ Meets or exceeds requirements of the NEC electrical codes; All standard components are UL rated
- ❖ Air flow velocity is factory set in accordance with Federal Standard 209E (90 ±20 FPM)
- ❖ Standard sized disposable fiberglass prefilter
- ❖ Three-piece access panels are easily removable and allow service to the top cabinet from the front, top or rear of the unit
- ❖ Extensive list of options available
- ❖ Selected sizes and options UL listed



For more information or to download or fax this product from the web, simply go to:

www.cleanairproducts.com/412

Series 412 Vertical Laminar Flow Clean Bench

Overview

The Series 412 vertical laminar flow clean benches consist of three basic components: The upper cabinet module houses the prefilters, HEPA or ULPA main filters, blower motors and lights. There is a lower support frame which is removable for easy shipment and moving. There are various options for the support frame, depending upon the application of the bench. The third major component is the lower work surface module which may be as simple as a flat table or as complex as a bench containing tanks, heated etch baths, gooseneck faucets, drains and other options. This modular design allows the clean bench to be easily shipped and assembled. Most sizes have been designed to fit thru standard doors and hallways. See the attached drawing and chart for

sizes on your specific model. There are a number of mode options that may be ordered depending where the air is to be directed or exhausted.

Construction

The upper cabinet module is constructed of welded 16 gage cold rolled steel that is finish ground to remove all sharp edges and painted with baked white enamel. This module houses the blower, motor, HEPA or ULPA filter, fluorescent lights, on/off switches, circuit breakers and electrical junction box.

Standard height of the upper cabinet is 30 inches. Its length and depth will depend upon the size and style of unit. Standard widths are 2-1/2 inches over nominal 3, 4, 5, 6, 8, 10 foot widths with interior depths of 30, 36, 42 and 54 inches (interior

table or working space). The overall cabinet width, depth and height will depend on the style of support frame and mode of operation.

The support frame is fabricated from heavy-duty 2x4 inch steel tubing. Horizontal cross bracing is 2x2 inch steel tubing. The open frame design permits cabinets to be butted end-to-end with no obstructions.

Finish

Standard finish is a white enamel that provides excellent corrosion protection. Custom colors are available.

Filters

The standard HEPA final filter is 99.99% efficient on particles 0.3 micron and larger. Most models have a final HEPA filter with an aluminum frame, white painted metal face guard



CAP412-6T30 Mode "WO" with solid white Formica table top and optional one-piece front access panel.



CAP412-4T30 Mode "E" with polypropylene exhaust plenum, storage cabinet, hinged front window, optional upper instrument beam, and lower plenum instrument panel.

and mini pleated filter media. Filters are removable through the front panel access. Optional ULPA filters, 99.999% on particles 0.12 micron, are available.

Negative Pressure Plenum for Final Filters: HEPA Or ULPA

The Series 412 utilizes flexible ducting connected from the blower to the HEPA filter. This ducting system provides negative pressure in the interior of the upper blower cabinet. The negative internal pressure is created by the blower drawing (sucking) air into the cabinet through the prefilters. The differential pressure drop across the prefilters creates the internal negative pressure. The entire interior of the upper cabinet, including the area that surrounds the HEPA filter, metal supply plenum and flexible ducting,

is also under negative pressure; thus preventing any gasket seal leaks from entering the work area. If a gasket leak does occur, the negative pressure area would “draw” the leaked air back to the blower where it is then ducted back to the HEPA filter and preventing the contamination from reaching the work area.

The negative pressure plenum system consists of a metal plenum that is clamped over the HEPA filter and held in place by a threaded rod and leaf spring. A flexible duct attaches between the metal supply plenum and blower for vibration isolation. To replace the HEPA filter, loosen and remove the flexible duct from the blower, loosen the fastener from the threaded rod and remove the leaf spring. Remove the metal supply plenum and lift out the HEPA filter.

To replace the HEPA filter, reverse the process. (See attached drawing showing cabinet dimension and chart showing filter size.)

Prefilter

The cabinet has a large prefilter area to keep the filtering efficiency high and minimize the pressure drop across the prefilters. The prefilters are housed on the top of the unit as standard but can be field relocated to the front or rear of the unit, if desired (see Note #1). The prefilters are a commonly available 20x25x1 disposable style that are interchangeable in size with prefilters of higher efficiency. The higher efficiency prefilters can be ordered with the unit or upgraded with the first prefilter change. Higher capacity (2 in. and 4 in. thick) prefilters can be installed on the top of the unit.



CAP412-4T30 Mode “O” with 4 post “KD” (Knock Down) support frame, three-piece front access panels, and optional minihelic pressure gage.



CAP412-8T30 Mode “E” with a stainless steel exhaust plenum, storage cabinet, hinged front window, optional upper instrument beam, and miscellaneous plenum accessories.

Series 412 Vertical Laminar Flow Clean Bench

Note #1: On the mode E, ER and R clean benches, or when the counterweighted sliding front window is ordered, the prefilters can only be located on the top of the unit. Consult factory for specific details.

Airflow

The air flow velocity is factory set in accordance with Federal Standard 209E (90 ±20 FPM). The blower-motor assembly is sized to provide proper air flow with a minimum 50% increase in HEPA filter pressure drop. This ensures years of bench operation without HEPA filter change.

Light Level

White fluorescent lamps will provide approximately 90 foot candle illumination 6 inches above a 36-inch work surface. An on/off switch is provided for lamp control.

The standard unit has T12 lamps. Selected units are available with T8 lamps and energy saving electronic ballast, however, they are not available in all sizes. T8 lamps must specifically be ordered. Consult factory for details. (See attached chart for the number of lamps and lamp type in the selected unit.)

Sound Level

The cabinets are designed for quiet operation. The typical sound level is approximately 65dba. Larger size units and those with multiple blowers may have a slightly higher sound level. The sound levels are measured with ambient of 55dba. The sound level of your particular unit may vary depending on the size of the unit surrounding room size and acoustics.

Electrical

Meets or exceeds requirements of the NEC electrical codes. The standard cabinet has a 120V, single-phase, 3-wire

electrical system. Selected units are available with optional UL labeling, which must be specifically requested and will be quoted as a line item.

Consult the factory for further details on UL listed cabinets. The UL label on the clean bench needs to be specifically ordered.

The electrical junction box is on the rear of the unit. Selected units can be provided with a power cord.

The blower motor has a variable solid state speed controller. Belt drive blowers (optional) use variable pitch pulleys for speed control. UL listed units have a multi speed tap for blower speed adjustment.

The upper cabinet contains the motor, light on/off switches, circuit breaker thermal protection and main cabinet power disconnect switch.

Blower/Motor Assembly

The system utilizes a PSC direct drive motor with a dynamically balanced blower wheel. This assembly is double vibration isolated from the cabinet to provide excellent vibration control. The motor itself is vibration isolated from the blower by multiple shear rubber isolation mounts. The blower/motor assembly is again vibration isolated from the cabinet by a second set of shear rubber vibration isolation mounts. The flexible duct connection between the blower and metal filter supply plenum also serves to further reduce vibration.

Each cabinet has a blower/motor assembly sized for reserve capacity to ensure a long HEPA filter life. A motor speed control mounted on the side of the blower can be adjusted to compensate for extra pressure drop caused by loading or contamination build-up on the HEPA filter surface.

Speed Control

A solid-state speed control is provided

to maintain correct air flow velocity. It has RFI suppression and transient high voltage protection.

Certification

Each cabinet is tested to Federal Standard 209E class 100 requirements. Every cabinet meets or exceeds this standard before it is allowed to ship.

Service Access

The three-piece access panels are easily removable and allow service to the top cabinet from the front, top or rear of the unit. The access panels are interchangeable to field convert the location of the prefilters.

A one-piece front panel is used with the counter-weighted sliding front window or when a slightly more decorative front is desired.

Options

- Face shields: hinged, fixed, or counter-weighted sliding
- Lower storage cabinets
- Gold fluorescent lamp sleeves
- ULPA filters 99.999%
- Ionization grids
- Cascades
- Ultrasonic cleaners
- Electrical outlets
- Etch tanks
- Sink for tanks — white or natural polypropylene, teflon or stainless steel
- Gooseneck — Polypropylene, PVC or PVDF for city or DI water
- Hand sprayers — Teflon for DI water or Teflon for N₂
- Gas/vacuum/air fixtures
- Extra height from table top to underside of blower filter cabinet
- Minihelic gauge — 0-2 inch differential pressure
- Special cabinet colors
- Flow-thru style lamp diffuser grill
- Top mounted electrical junction box

- Prefilter location from top to front
 - Power cord — 8 ft, 3 wire — available for units under 20 amps
 - Suspended ceiling vs. support frame — (4) threaded hanger holes
 - Pneumatic and tank drains valves
 - Additional electrical receptacle
 - DI water loop
 - Plenum drain
 - Wiring/blower assembly for hazardous materials/areas
 - Other types of process tanks available but not listed
 - Timers
 - Controllers
 - Hot plates
 - Gas cocks
 - Flow meters
 - Plenum flushing system
 - Alarms
 - Selected sizes and options UL listed
- The complete list of available options is quite extensive — the most common are listed above. Clean Air Products has an experienced in-house engineering staff. This enables us to modify the Series 412 to meet our customers' bench requirements.

Blower, Motor, Electrical, and Filter Sizes

Model	HEPA Filter	Prefilter	Blower	Motor	Lamp	Electrical*
3T30	(1) 24x36x3	(1) 20x25x1	(1) DD-10-6	(1) 1/2HP PSC	(2)	120V/1Ø/60HZ 9.7 amp*
4T30	(1) 24x48x3	(2) 20x25x1	(1) DD-10-6	(1) 1/2HP PSC	(2)	120V/1Ø/60HZ 9.7 amp*
5T30	(1) 24x60x3	(2) 20x25x1	(1) DD-10-8	(1) 1/2HP PSC	(2)	120V/1Ø/60HZ 12.5 amp*
6T30	(1) 24x72x3	(3) 20x25x1	(1) DD-10-8	(1) 1/2HP PSC	(2)	120V/1Ø/60HZ 12.5 amp*
8T30	(2) 24x48x3	(4) 20x25x1	(2) DD-10-6	(2) 1/2HP PSC	(2)	120V/1Ø/60HZ 15.2 amp*
10T30	(2) 24x60x3	(5) 20x25x1	(2) DD-10-8	(2) 1/2HP PSC	(2)	120V/1Ø/60HZ 19.95 amp*
3T36	(1) 30x36x3	(1) 20x25x1	(1) DD-10-6	(1) 1/2HP PSC	(2)	120V/1Ø/60HZ 9.7 amp*
4T36	(1) 30x48x3	(2) 20x25x1	(1) DD-10-8	(1) 1/2HP PSC	(2)	120V/1Ø/60HZ 12.5 amp*
5T36	(1) 30x60x3	(2) 20x25x1	(1) DD-10-8	(1) 1/2HP PSC	(2)	120V/1Ø/60HZ 12.5 amp*
6T36	(1) 30x72x3	(3) 20x25x1	(1) DD-10-8	(1) 3/4HP PSC	(2)	120V/1Ø/60HZ 14.7 amp*
8T36	(2) 30x48x3	(4) 20x25x1	(2) DD-10-8	(2) 1/2HP PSC	(2)	120V/1Ø/60HZ 19.95 amp*
10T36	(2) 30x60x3	(5) 20x25x1	(2) DD-10-8	(2) 3/4HP PSC	(2)	120V/1Ø/60HZ 19.95 amp*
3T42	(1) 36x36x3	(1) 20x20x1	(1) DD-10-6	(1) 1/2HP PSC	(4)	120V/1Ø/60HZ 12.5 amp*
4T42	(1) 36x48x3	(2) 20x25x1	(1) DD-10-8	(1) 1/2HP PSC	(4)	120V/1Ø/60HZ 14.4 amp*
5T42	(2) 36x30x3	(2) 20x25x1	(1) DD-10-8	(1) 3/4HP PSC	(4)	120V/1Ø/60HZ 14.4 amp*
6T42	(2) 36x36x3	(3) 20x25x1	(2) DD-10-6	(2) 1/2HP PSC	(4)	120V/1Ø/60HZ 19.8 amp*
8T42	(2) 36x48x3	(4) 20x25x1	(2) DD-10-8	(2) 1/2HP PSC	(4)	120V/1Ø/60HZ 19.8 amp*
10T42	(2) 36x60x3	(5) 20x25x1	(2) DD-10-8	(2) 3/4HP PSC	(4)	120V/1Ø/60HZ 24.4 amp*

* Includes 4 amp receptacle.

Series 412 Vertical Laminar Flow Clean Bench

Front Laminar Flow Shield and Window Options

- 6-inch flexible laminar flow guide is standard
- Ergonomic hinged front face shield
- Counterweighted vertical sliding front window
- Safety glass upgrade for hinged or sliding front window

The 6-inch front laminar flow guides, face shields, ergonomic hinged face shield or counterweighted sliding windows are designed to isolate and contain the “clean air” within the bench from outside contamination. The type of front shield used can be dependent on the style of bench and the exterior environment.

The 6-inch laminar flow guide helps air develop “laminar flow” in much the same way as a water nozzle on a hose. The shield is short and flexible, so it typically does not interfere with work in the bench. This shield is installed on the shear edge of the HEPA/ULPA filter. It works in conjunction with the end shields which are also located on the shear edge of the filter. As the air comes out of HEPA/ULPA filter, the air has some surface turbulence caused by the configuration of the pleats of the filter. It takes a few inches for the airflow to develop into smooth laminar flow, similar to a water nozzle on a fire hose. Once the air flow leaves the front guide, it still has the side end panels to guide it downward about 12 to 18 inches before there is significant deterioration of the laminar flow. As the air is flowing downward it is also flowing out of the clean bench, because it is confined on the back and sides. This outflow helps prevent contamination from entering the critical work space.

The standard distance between the table top and underside of the top filter cabinet is 28 inches with a 36-inch table

top height. When this height changes, either by lowering the table height or making the support “C” frame taller, this face shield becomes even more important and is recommended to increase the length of this guide.

When items are placed within the work area or the operators work inside the bench they can cause turbulence and disrupt the airflow. This turbulence can cause air currents within the bench that would allow outside air to be drawn into the bench because of the energy created by the turbulence.

When turbulence within the bench becomes a concern, a face shield is often installed onto the bench. The ergonomic hinged acrylic face shield is typically installed to create a 12-inch opening on the front of the working area. The face shield guides the laminar flow down closer to the table top and vents the air out of the cabinet through a smaller front opening. The smaller front opening creates a higher exit velocity that reduces the chance of inflow contamination.

In addition to improved airflow and higher pressurization of the work area, the ergonomic hinged front window provides a physical barrier between the operator and the interior clean area. The ergonomic hinged front window is recessed 5 inches at the top and slopes out towards the front edge of the table. This 5-inch recess allows the operator to lean forward and work in a more natural, ergonomic position while their arms are below the window. The window prevents them from leaning too far into the work area causing the blockage of the down flow air, creating turbulence and the introduction of unwanted contamination into the work area.

Cabinet Support Frames

The upper cabinet can be supported in a variety of ways depending on the

application. The most common are “C”, “CR”, “T”, “KD”, and “SP” frames. Each type of frame is designed for a different type of application. Please consult the factory for additional options.

“C” Frame: The “C” frame is constructed with 2x4 tubular steel that is welded, finished ground and painted with a white baked enamel finish. The front of the “C” frame is open to allow multiple cabinets to be set side by side for a continuous work area. Each frame is furnished with 4 adjustable leg leveling glides.

The frame has a removable clear acrylic panel located on each end of the frame. These panels are installed on the shear edge of the laminar airflow to create a smooth, non-turbulent end boundary for the clean work space. If the units are set side-by-side with the clear end panels removed, work may be easily passed from one station to the next.

The rear of the support frame is enclosed by a solid back panel that is available in a variety of materials. The standard is white vinyl covered steel, however, options include painted steel, stainless steel, white polypropylene or clear acrylic.

Various cabinet options can be installed into this basic support frame. These include built-in solid, perforated or wire table top, exhaust plenum or a 95% air recirculation system.

“CR” Frame (C frame with reinforcing post): The “CR” frame is the same as the “C” frame except for extra vertical reinforcing supports. These vertical supports may be required on some larger systems with heavier top cabinets. The vertical support may be mounted midway back on the frame or on the front edge depending on the “Mode” of the cabinet.

“T” Frame: The “T” frame is designed to allow access to both the

front and rear of the clean bench and to have an open side. A typical application would be bench assembly of small parts where multiple clean benches are placed side-by-side with operators sitting at both the front and rear of the clean bench. With the side plex removed and the open sides of the "T" frame, parts can easily be slid from one bench to another, without having to be taken out of the clean bench area. By working from both sides of the bench you can double the amount of assemblers working per clean bench, reducing the capital cost per employee and conserving floor space.

The table tops on the "T" Series frames can be extended to accommodate a larger (deeper) work surface with a smaller upper filter cabinet. The "T" series of clean benches can achieve Class 100 cleanliness. The extended table options are most often used in applications that do not require critical Class 100 conditions. Depending on the application and the length of the table extension, we recommend having a modified face shield. Consult the factory for details.

The "T" frame system, when used in a row of benches, is designed to have the vertical support "T" frames share the upper filter cabinets — reducing the cost and the bulk of the support frame. It is important to know the assembled configuration to provide the correct combination of supports and table tops.

"KDFP" Frame (Knock down frame): The 4-post support frame is made up of four 2x2 tubular steel legs that bolt onto the outer ends of the top cabinet. The Plexiglas end panels mount on the inside surface of the 2x2 tubular steel legs. The bolt-on legs and back panel ship knocked down, allowing a smaller and more compact shipping package.

Optional removal of the back panel allows easy interior access from both the front and rear of the clean bench. Some applications, when the back panel is removed, will require larger support legs to prevent side sway. This is typically required only for seismic areas.

Multiple units may be put end to end, forming a continuous line. The units can be made with a common set of support posts between two adjoining top cabinets. This option should be specified, as it requires an additional set of support leg mounting holes, however, the units are field convertible to this configuration. This is an ideal system for export because of the small shipping package and ease of assembly. The sharing of support frames is an option and must be specifically quoted to avoid field modifications.

"KDAF" Frame (Knock down frame): The two-end support sections have an "A" shape welded end support section. There is a front and rear vertical support post with an upper and lower cross tube. The Plexiglas end panels mount in shear with the edge of the HEPA filter for improved airflow and mount to the inside surface of the side support frame. The back panel screws to the rear of the side frame supports. The end support sections and back panel knock down for a smaller more compact shipping package.

The unit can be furnished with a built-in table top or free-standing table.

Note: The inside clear width between the side supports is 2 inches less than the even foot. Please take this into account if you are sliding an existing table or piece of equipment into the bench.

"SP" Frame (Straddle post): The straddle post frame can be made with an extended support leg frame that will allow mounting over a machine.

Consult the factory for details on your application.

Seismic Floor Supports: Clean Air Products can provide seismic floor mounting angles, support, or threaded hanger supports on its equipment. Consult the factory for specific details on your individual equipment.

Cabinet Operation (Modes)

Note: The options listed below may be the most common for that "Mode" type. There is a more complete listing of options on page 5.

Mode "O" (Open Base)

The Mode "O" or open base upper cabinet is mounted on a support frame with an open area below. This allows a space where a separate vibration isolated table may be located within the work space.

The standard Mode "O" is furnished with a top cabinet that contains: 120 VAC, 60 Hz blower motor assembly, 99.99% efficient HEPA filter, white fluorescent lights, white vinyl covered steel back panel, clear acrylic end panels and "C" style support frame.

Common options available with either the "C", "CR" frame or "KD" frame are hinged or counterweighted sliding window, Series 61 Formica table, Series 62 stainless steel table or Series 64 perforated stainless steel stand alone tables.

The inside width of the support frame is about 1-1/2 inches under the even foot. (i.e. 6-foot cabinet would be 70-1/2 inches between the floor supports and 70 inches between the end panels.) If tables or other types of workstations are being used inside the bench that are even feet in length (i.e. 72 inches), Clean Air Products can adjust the height of the end panels so that they will stop above the height of the table.

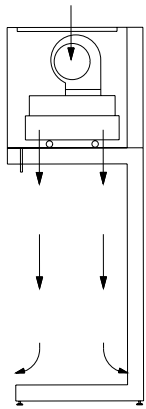

MODE O

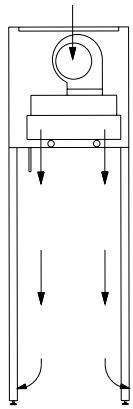

4 POST
KD-MODE O
KD-MODE WO
KD-MODE WT
KD-MODE E

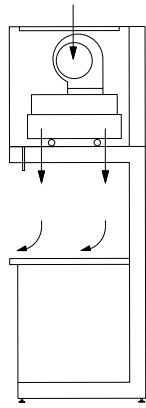

MODE WO

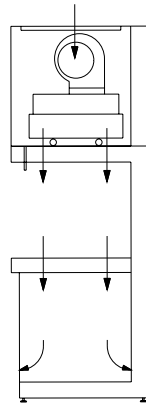

MODE WT

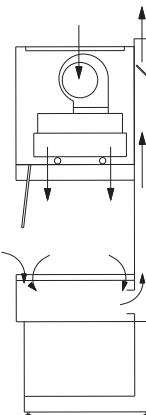

MODE E

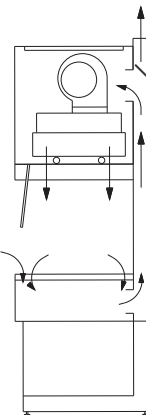

MODE ER

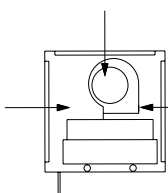

PREFILTERS CAN BE LOCATED ON THE TOP, FRONT, OR BACK AND ARE FIELD CONVERTABLE

Mode “WO” (Wash Out)

The Mode “WO” (Wash Out) has a built-in table top. The clean HEPA filtered air flows down from the upper filter cabinet onto the work area providing a Class 100 or Class 10 working environment. The air exits (washes out) from the front of the cabinet preventing outside contamination from entering the hood.

The standard Mode “WO” is furnished with a top cabinet that contains: 120 VAC, 60 Hz blower motor assembly, 99.99% efficient HEPA filter, white fluorescent lights, white vinyl covered steel back panel, clear acrylic end panels, white laminate table top, and “C” style support frame. Optional table tops are available in colored laminate, static dissipative laminate, stainless steel, and liquid-tight recessed center stainless steel. Support frame options are “C”, “CR” “T” and “KD”

Other common options are a lower storage cabinet, hinged front window, or counterweighted sliding front window.

Note: The storage cabinet can be recessed to allow knee clearance for operations that require sitting.

Mode “WT” (Wash Thru)

The Mode “WT” has a built in perforated stainless steel perforated table top. The airflow on this model flows down from the HEPA filter and through the perforated table top. This creates a more true vertical laminar airflow within the work area.

Common options include either a hinged or counterweighted sliding front window and the stainless steel back panel.

Mode “E” (Exhausting) and “ER” (Exhaust/Recirculating)

The Mode “E” or exhaust cabinet has a work area table top with a

liquid-tight air exhaust plenum below. The table top is constructed of a solid center section with a front and rear exhaust grill. The cabinet is designed to prevent fumes from leaving the cabinet while maintaining a Class 100 or Class 10 working environment within the hood.

The airflow direction within the clean bench is as follows: clean air flows down from the HEPA filter onto the work space creating an ultra clean working environment. The front exhaust grill draws room air into the 8 to 10-inch opening and down into the plenum. This provides an “air curtain” interface between the room air and clean interior environment. The rear exhaust grill draws the clean filtered air from the hood. The “ER” or exhaust/recirculating Mode operates the same as the mode “E” except that a portion of the air is recirculated back to the blower where it is refiltered by the HEPA filter.

The front exhaust connects to the cabinet exhaust duct located on the rear of the cabinet. The cabinet duct connects directly to the exhaust plenum at a point below the table top and flows upward along the rear and terminates approximately 2 inches above the top cabinet. The Mode “E” and Mode “ER” require either hinged or counterweighted sliding window options.

Most applications prefer the exhaust blower to be at the point of discharge to maintain negative exhaust duct pressure, so an exhaust blower is not included with the unit.

Selected models have been air flow tested to fume containment test #ASHRA 11-1985. The test units were equipped with hinged or counterweighted sliding windows with 12-inch work openings.

The interior work area can be made of stainless steel, white polypropylene,

or fire retardant white polypropylene.

Storage Cabinets, Lower

Storage cabinets can be provided below tabletop on the Mode "WO" or below the exhaust plenum on the Mode "E" and Mode "ER."

Note: Storage cabinets on the Mode "WT" are typically not used because they would block the airflow going through the table.

The lower storage cabinet can be recessed back 12 inches to allow knee clearance for operations that require sitting.

Drawers

Drawers can be installed below the table. Drawers are nominal 3 inches, 6 inches, and 12 inches deep. They can be configured as singles or in stacks, and depths can be mixed. See drawer specification sheet for additional detail.

All-Polypropylene Lower Support Frame

The all-polypropylene lower support frame option removes the metal support frame and replaces it with an all-polypropylene support stand. The unit is available with or without the lower storage cabinet. The lower support frame can be made with the standard width which is 2-1/2 inches over the even foot (74-1/2 inches on a 6-foot bench with 70-inch clear working area) or the wide support frame which is 12-1/2 inches over the even foot or 84-1/2 inches wide outside with a 70-inch inside working area. The extra width is to allow controls and valves to be mounted on the sides rather than on the front of the unit.

Note: With the all-polypropylene lower support frame, the sides are a welded integral part of the lower support assembly. You are not able to remove the side shields as is available

with the metal "C" support frame. If the benches are to be lined up side-by-side and have items passed to the side, an access hole must be ordered.

All-Polypropylene Lower Support and Filter Cabinet Shell

This unit has the all-polypropylene lower support frame combined with an all-polypropylene upper filter cabinet shell. With this, the light is mounted exterior and mounted inside a polypropylene light shield. Included are a Teflon-coated blower wheel and plastic blower housing. There is a minimum of exposed metal on the unit.

Common options include: hinged window, counterweighted sliding front window, lower storage cabinet, stainless steel or polypropylene interior, sinks, goosenecks, hand sprayers and N₂ guns.

Specifications

Meets requirements of the National Electrical Codes.

The unit is ready for operation and certified to meet or exceed Class 100 conditions of Federal Standard 209E after the upper cabinet is attached to the lower support frame. The two components are packed separately.

Operation manual and test reports are provided with shipment.

Support Structure

The "C" frame is constructed of welded 2x4 cold rolled tubular steel that has a white baked enamel finish.

The "KD" frame is constructed of four 2x2 cold rolled steel tubular members that receive a white baked enamel finish.

Table Top, Exhaust Plenum, Back Panel and Exhaust Duct

- Stainless steel Type 304 #4 finish
- White polypropylene

- White fire-retardant polypropylene
- Others

The table top and exhaust grills are removable, exposing the exhaust plenum. The plenum is liquid tight and slopes to the plenum drain. The exhaust duct slopes into the exhaust plenum which includes a volume control damper.

Work Area End Panels

The work area end panels are attached to the interior end support frame and terminate approximately 30.0 inches from the base of the end support frame.

- Clear acrylic (standard)
- 304 stainless steel (optional)
- White polypropylene (optional)
- Cold rolled steel with white baked enamel (optional)
- Other _____

Front Viewing Windows

The front viewing windows attached to the front of the air supply module.

- 6.0 in. flexible clear polished vinyl (standard)
- 12.0 in. fixed clear acrylic (optional)
- 12.0 in. hinged clear acrylic (optional)
- Counterweight sliding front window clear acrylic (optional)

Series 412 Vertical Laminar Flow Clean Bench

Interior Work Area Dimensions (Standard)

Depth in inches (front to rear)

- T30 Series = 30.0
- T36 Series = 36.0
- T42 Series = 42.0

Width in inches (end to end)

- Nominal 3 ft. = 34
- Nominal 4 ft. = 46
- Nominal 5 ft. = 58
- Nominal 6 ft. = 70
- Nominal 7 ft. = 82
- Nominal 8 ft. = 94
- Nominal 9 ft. = 106
- Nominal 10 ft. = 118

Height will depend upon the height of the table or bench top from the floor. The height from the floor to the bottom of the upper cabinet module is 64.0 inches with the standard frame. The standard bench top height is 36.0 inches.

Overall Dimensions (Standard)

Height: 94.0 inches, floor to top of upper cabinet module.

NOTE: Allow a minimum of 1.25 inches over the top of the unit for airflow and servicing of the prefilters.

Depth in inches (front to rear)

- T30 Series = 34 front to rear
- T36 Series = 40 front to rear
- T42 Series = 46 front to rear

Note: A counterweight sliding front window increases the overall depth by 1.5 inches. Mode "ER" increases overall depth by 2 inches.

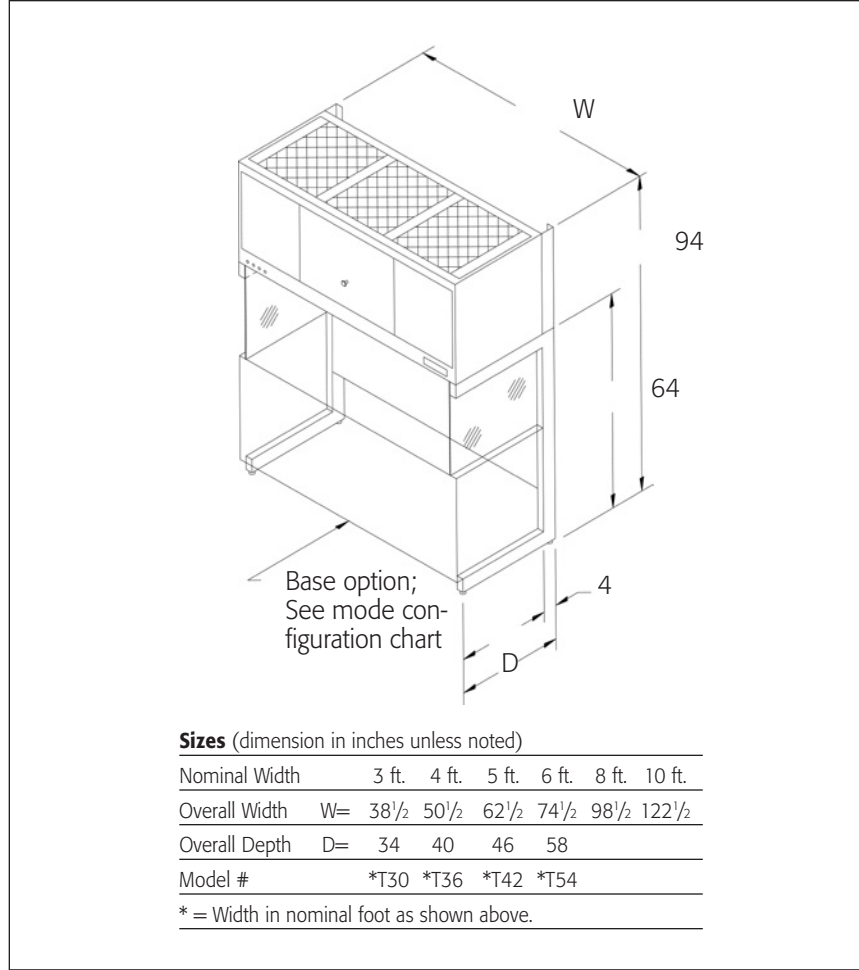

Width in inches: (end to end)

- 3 ft. = 38.5
- 4 ft. = 50.5
- 5 ft. = 62.5
- 6 ft. = 74.5
- 7 ft. = 84.5
- 8 ft. = 98.5
- 9 ft. = 110.5
- 10 ft. = 122.5

Part Number Configuration

Model Number CAP412-6T30 WO is for a 6-foot nominal width and "T30" is for a 30-inch deep work depth. The "WO" indicates a wash out style clean bench configuration.

Estimated Weights for Standard Benches

3T30 = 440 lb.	6T36 = 750 lb.
3T36 = 570 lb.	6T42 = 910 lb.
3T42 = 700 lb.	8T30 = 765 lb.
4T30 = 490 lb.	8T36 = 920 lb.
4T36 = 630 lb.	8T42 = 1100 lb.
4T42 = 790 lb.	10T30 = 940 lb.
5T30 = 540 lb.	10T36 = 1040 lb.
5T36 = 690 lb.	10T42 = 1240 lb.
5T42 = 840 lb.	Standard units shipped F.O.B. factory by padded van.
6T30 = 590 lb.	

Upper cabinet module and support frame assemblies are shipped on separate skids. (Assembly is required.)

Specifications subject to change. Please contact factory for details.