

General Description

The Series 301 horizontal flow clean bench is specifically designed to create a free standing ultra clean environment. This clean bench is available in various sizes with various options. These varied sizes and options provide excellent solutions to many air filtration applications.

Systems can be one single vertical flow bench with open interiors to numerous units coupled together to form a continuous work area with complex accessories.

Cabinet

The Series 301 cabinets consist of heavy 18 gauge white Vinclad (vinyl clad steel) exterior finish. The vinyl is 8 to 10 mils in thickness and is laminated to provide an attractive appearance and toughness. It is superior to paint and plastic laminate over board material. It is resistant to abrasion, corrosion, stains, and attacks by chemicals. Vinclad will not support combustion; it is resistant to scratching, scuffing, crazing or cracking and will not chip. Vinclad is peel proof and has moderate acoustical control.

A unique "Wrap-Around" cabinet design is used to achieve excellent appearance and ruggedness through the exclusive use of metal components.

The clean HEPA filtered air flows horizontally from the cabinet. The cabinet puts the built-in table top in shear with the media edge of the HEPA filter.

The clean bench cabinet houses blower, motor, the HEPA or ULPA filter, fluorescent lights, on/off switches, circuit breakers and electrical junction box.

Most sizes fit through standard doors and hallways. See the attached drawing and chart for sizes on your specific model.

Features

The Series 301 clean bench cabinet is an all-metal construction with a Vinclad exterior.

The table work surface is fabricated of white plastic laminate over particle board. This surface provides a durable, cleanable and attractive surface.

Two white fluorescent lamps, with energy efficient ballast, are provided to illuminate the work area. An on/off switch is provided for lamp control.

The work area hood assembly is fabricated of clear acrylic. The hood provides a controlled work area and assists in directional air flow.

Standard floor to table top height is 30 inches. The length and height will depend on the process it is used for. Standard widths are 2-1/2 inches over nominal 3, 4, 5, 6, 8 increments and the interior depth (interior table or working space) of 21-1/2 inches. The overall cabinet width, depth and height will depend on the size of unit chosen.

Electrical

The electrical requirement is 120V, single-phase, 3-wire system with 8 foot flex power cord (up to 15 amps) or hard wiring exiting the back side of the unit.

The motor speed is infinitely variable with Solid State controller.

The electrical outlet is a 15 amp duplex installed in the base right front under the table and is used for auxiliary equipment. The power available for this receptacle is 3 to 5 amps, unless otherwise specified.

The system provides independent motor and light on/off switches.

The direct drive motor and dynamically balanced blower assembly is isolated from cabinet by rubber mounts and by the HEPA Flex Duct connection.

The system meets requirements of the NEC electrical codes and includes UL recognized components.

Motor/Blower

The system utilizes a PSC direct drive motor with a dynamically balanced blower wheel. The assembly is double vibration isolated from cabinet to provide excellent vibration control. The motor is vibration isolated from the blower by multiple in shear

Series 301



 For more information or to download or fax this product from the web, simply go to:
www.cleanairproducts.com/301

Series 301 Horizontal Flow Clean Bench

Technical Data continued

rubber isolation mounts. The blower/motor assembly is again vibration isolated from the cabinet by a second set of shear rubber vibration isolation mounts. The Flex Duct connection between the blower and HEPA filter also serves to further reduce vibration.

Each cabinet has a blower/motor assembly sized for reserve capacity to ensure a long HEPA filter life. A motor speed control mounted on the side of the blower can be adjusted to compensate for extra pressure drop caused by loading or contamination build-up on the HEPA filter surface.

Fluorescent Lighting

White fluorescent lamps are provided to illuminate the work area. An on/off switch is provided for lamp control. This will provide approximately 100 foot candle illumination 24 inches below the hood top.

The standard unit has T12 lamps. Selected units are available with T8 lamps and energy saving electronic ballast. The new energy saving lamps and ballast are not available in all sizes. T8 lamps must be specifically ordered. Consult factory for details.

See chart for the number of lamps and lamp type in the selected unit.

Work Area Top and End Enclosure Panels

There is an end panel at each end of the table top. The end panels are table top width and extend to the top of the unit where they join the top enclosure panel. (See enclosure height in working dimension section.) The top and end panels are attached together to form a one-piece enclosure. This enclosure is fastened to the cabinet along the edges of the top and the end panels.

Air Flow

The air flow for the unit is factory set at an average filter face velocity of approximately 90 FPM. This velocity is maintained by adjusting blower speed as filter pressure increases with over period of use.

Sound Level

The cabinets are designed for quiet operation. The typical sound level is approximately 65dba. Larger size units and those with multiple blowers may have a slightly higher sound level. The sound levels are measured with ambient of 55dba. The sound level of your particular unit may vary depending on the size of the unit surrounding room size and acoustics.

Final Filters: HEPA or ULPA

The final filter is 99.99% effective on 0.3 micron and larger particles. Standard final filters have an aluminum anodized frame, painted white metal faceguard and mini pleated filter media construction. Filters are removable through the table top enclosure area. Optional ULPA filters, 99.999% on .12 micron are available.

Negative Pressure Plenum for Final Filters: HEPA or ULPA

The Series 301 utilizes the HEPA FLEX duct system to provide air flow from the blower to the HEPA filter. This ducting system in conjunction with the cabinet blower provides a negative pressure area on the cabinet interior. The negative pressure serves as a safety seal that prevents gasket leaks which can occur in positive pressured filter systems.

Flex Duct

The negative internal pressure is created by the blower drawing (sucking) air into the cabinet through the prefilters. The differential pressure drop across the prefilters is what creates the internal negative pressure. The entire interior of the cabinet, including the area that surrounds the HEPA filter and flexible ducting, are also under negative pressure. This negative pressure prevents any gasket seal leaks from entering the work area. If a leak does occur, it is "sucked" back to the blower where it is then ducted back to the HEPA filter.

HEPA/ULPA Filter Replacement

The HEPA or ULPA filter are serviced from the front of the unit.

Prefilters

The 1.0 inch fiberglass prefilter is removable from the front lower cabinet and is accessible behind hinged prefilter grill.

The cabinet has a large prefilter area to keep the filtering efficiency high and to minimize the pressure drop across the prefilters. The prefilters are shipped in lace. The cabinets have a commonly available 20x25x1 and 20x20x1 disposable prefilter style depending on its size. These prefilters are interchangeable in size with prefilters of higher efficiency. The higher efficiency prefilters can be ordered with the unit or upgraded with the first prefilter change.

Filter Sizes

Front HEPA filter area based on the following example:
 301-624 (624 = 6 ft. long x 24 inches high)

301-24 HEPA Filters			Prefilters	
324	(1)	24x36x3	(1)	20x20
424	(1)	24x48x3	(1)	20x25
524	(2)	24x30x3	(2)	20x20
624	(1)	24x72x3	(2)	20x25
824	(2)	23-5/8x47-5/8x3	(3)	20x25
301-30 HEPA Filters			Prefilters	
330	(1)	30x36x3	(1)	20x20
430	(1)	30x48x3	(1)	20x25
530	(1)	30x60x3	(2)	20x20
630	(1)	30x72x3	(2)	20x25
830	(2)	30x48x3	(3)	20x25
301-36 HEPA Filters			Prefilters	
336	(1)	36x36x3	(1)	20x20
436	(1)	36x48x3	(1)	20x25
536	(1)	36x60x3	(2)	20x20
636	(2)	36x36x3	(2)	20x25
836	(2)	36x48x3	(3)	20x25
301-48 HEPA Filters			Prefilters	
448	(1)	47-1/4x47-5/8x3	(1)	20x25
548	(2)	48x30x3	(2)	20x20
648	(2)	48x36x3	(2)	20x25
848	(2)	47-1/4x47-5/8x3	(3)	20x25

Electrical Information and Blower Motor Sizes

301-24	Blower	Motor	Fluorescent Lamp	Electrical
324	(1) DD-10-4	1/3HP PSC	(2)	120V/60HZ 7.9 amp
424	(1) DD-10-6	1/2HP PSC	(2)	120V/60HZ 9.4 amp
524	(1) DD-10-8	1/2HP PSC	(2)	120V/60HZ 9.4 amp
624	(1) DD-10-8	1/2HP PSC	(2)	120V/60HZ 9.4 amp
824	(1) DD-10-6	1/2HP PSC	(2)	120V/60HZ 17.4 amp
301-30				
330	(1) DD-10-6	1/3HP PSC	(2)	120V/60HZ 7.9 amp
430	(1) DD-10-8	1/2HP PSC	(2)	120V/60HZ 9.4 amp
530	(1) DD-10-8	1/2HP PSC	(2)	120V/60HZ 9.4 amp
630	(1) DD-10-8	3/4HP PSC	(2)	120V/60HZ 12.4 amp
830	(2) DD-10-6	1/2HP PSC	(2)	120V/60HZ 17.4 amp
301-36				
336	(1) DD-10-8	1/2HP PSC	(2)	120V/60HZ 9.4 amp
436	(1) DD-10-8	1/2HP PSC	(2)	120V/60HZ 9.4 amp
536	(1) DD-10-8	3/4HP PSC	(2)	120V/60HZ 12.4 amp
636	(2) DD-10-8	1/2HP PSC	(2)	120V/60HZ 17.4 amp
836	(2) DD-10-6	1/2HP PSC	(2)	120V/60HZ 17.4 amp
301-48				
448	(1) DD-10-8	3/4HP PSC	(2)	120V/60HZ 12.4 amp
548	(2) DD-10-8	1/2HP PSC	(2)	120V/60HZ 17.4 amp
648	(2) DD-10-8	1/2HP PSC	(2)	120V/60HZ 17.4 amp
848	(2) DD-10-6	3/4HP PSC	(2)	120V/60HZ 23.4 amp

Overall Dimensions

Overall Width of Cabinet (floor to top of cabinet): Dimension "A"

- ___ 3 foot = 38-1/2 in.
- ___ 4 foot = 50-1/2 in.
- ___ 5 foot = 62-1/2 in.
- ___ 6 foot = 64-1/2 in.
- ___ 8 foot = 98-1/2 in.

Overall Depth of Cabinet (front to back): 34 in.

(Power cord or hard electrical connection on the rear of the unit.)

Overall Height of Cabinet (distance from floor to top of unit): Dimension "D"

(Add 6.0 inches for 36-inch high table top option.)

- ___ 58.0 in. (24 Series)
- ___ 64.0 in. (30 Series)
- ___ 70.0 in. (36 Series)
- ___ 82.0 in. (48 Series)

Work Area Dimensions

Table Top Depth (table outside edge to cabinet HEPA filter):

21-1/2 in.

Table Top Height: 30.0 in. from floor ±.75 in. with leg levelers

Work Area Internal Height (distance from top enclosure panel to table top surface): Dimension "B"

- ___ 22 in. (24 Series)
- ___ 28 in. (30 Series)
- ___ 34 in. (36 Series)
- ___ 46 in. (48 Series)

Series 301 Horizontal Flow Clean Bench

Technical Data continued

**Work Area Internal Width
(distance between end panels):
Dimension "C"**

- 3 foot = 34 in.
- 4 foot = 46 in.
- 5 foot = 58 in.
- 6 foot = 70 in.
- 8 foot = 94 in.

Optional Accessories

- "Minihelic" 0 to 2 inch differential pressure gauge. (HEPA)
- Stainless steel table top
- Table top support legs
- Gas cock
- Electrical duplex outlet (additional)
- Bar and hooks for bottle hanging
- Gold fluorescent lamps
- Fluorescent gold lamp sleeves
- Safety glass hood
- 36 inch table top height
- Conductive Formica top
- Anti-static grid and power supply
- Painted cabinet – color code, manufacturer and chip required
- Hood depth – extended (standard 21-1/2 inch) front leg supports are recommended)
- End panels – RH LH
- End panels – stainless steel
- Table top – rolled front edge
- Casters with locking brake
- Metal plenum vs. standard Flex Duct
- 175 footcandles – 4 lamp fluorescent lighting at table top
- HEPA filter grill – perforated stainless grill – removable
- Hood – safety glass top with stainless steel end panels
- Drawers and storage trays
- Foot rest
- Cabinet shell – all stainless steel

Shipped fully assembled ready for operation and certified to meet or exceed Class 100 conditions of Federal Standard 209D.

Operations manual and test reports provided with unit at shipment.

Estimated Weight**301*24**

- 324 = 370 lb.
- 424 = 400 lb.
- 524 = 450 lb.
- 624 = 500 lb.
- 824 = 880 lb.

301*30

- 330 = 400 lb.
- 430 = 450 lb.
- 530 = 500 lb.
- 630 = 550 lb.
- 830 = 770 lb.

301*36

- 336 = 450 lb.
- 436 = 500 lb.
- 536 = 550 lb.
- 636 = 600 lb.
- 836 = 800 lb.

301*48

- 448 = 570 lb.
- 548 = 650 lb.
- 648 = 750 lb.
- 848 = 900 lb.

Standard units shipped F.O.B. factory by padded van.

Equipment specification, dimensions and upgrades are subject to change without notice.

Series 301

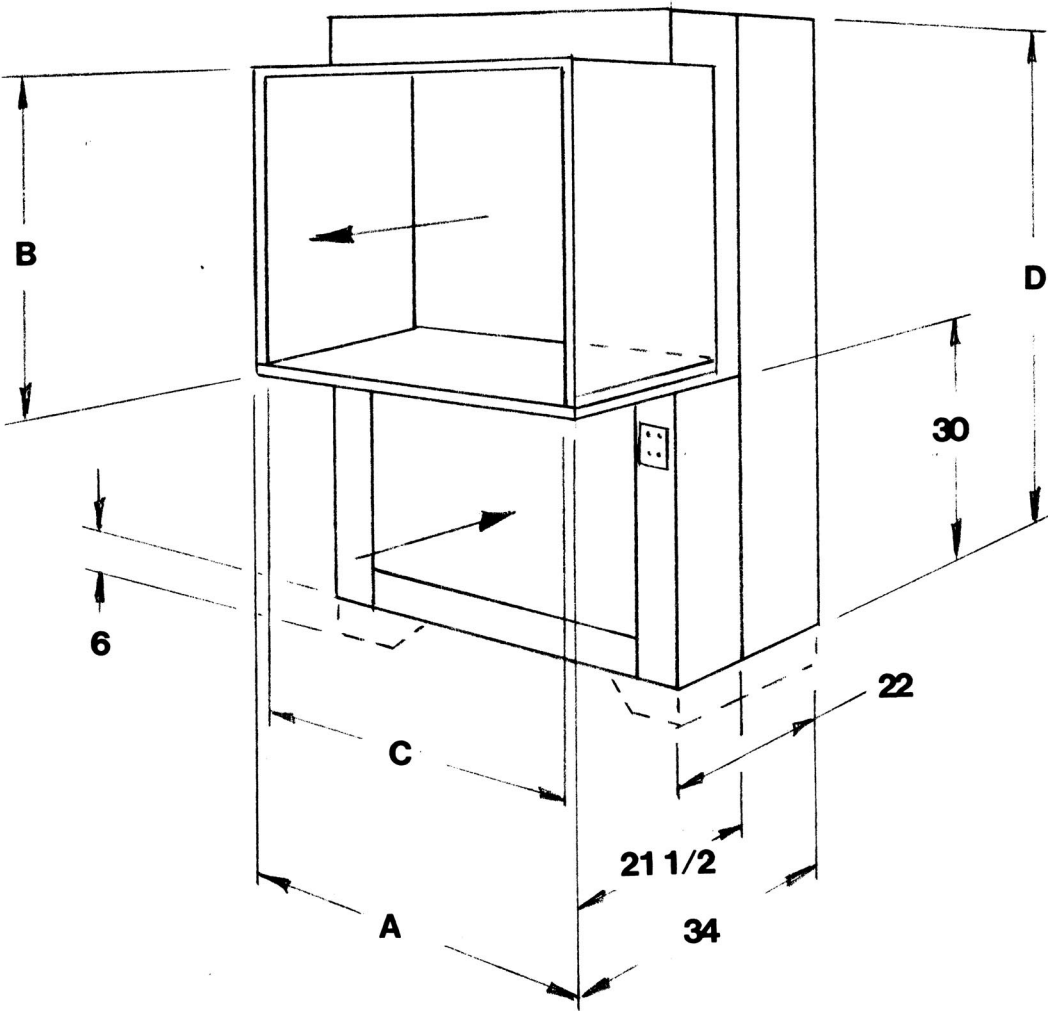

Specifications subject to change. Please contact factory for details.



Solutions Built to Your Specifications.

8605 Wyoming Ave. N. • Minneapolis MN 55445
 tel: 763.425.9122 800.423.9728 fax: 763.425.2004
 e-mail: sales@cleanairproducts.com www.cleanairproducts.com